



SEZIONATORI DISCONNECTING SWITCHES

Sezionatori
Switches

Accessori
Accessories



Alogiene a bassissima tensione
Very low voltage halogen

Alogiene a tensione di rete
Mains voltage halogen

Scarica
Discharge

Incandescenza
Incandescent

SEZIONATORI SWITCHES

250V	Versioni <i>Constructive versions</i>		06
	0125	2 poli 2 pole	08
	0126	3 poli 3 pole	10
	0127	2 poli + terra 2 pole + earth	12
400V	Versioni <i>Constructive versions</i>		14
	0130	2 poli 2 pole	16
	0131	3 poli 3 pole	18
	0132	2 poli + terra 2 pole + earth	20

SEZIONATORI DISCONNECTING SWITCHES

Serie 0125 - 0126 - 0127 - 0130 - 0131 - 0132

Basetta maschio (spina) Male terminal strip (socket)

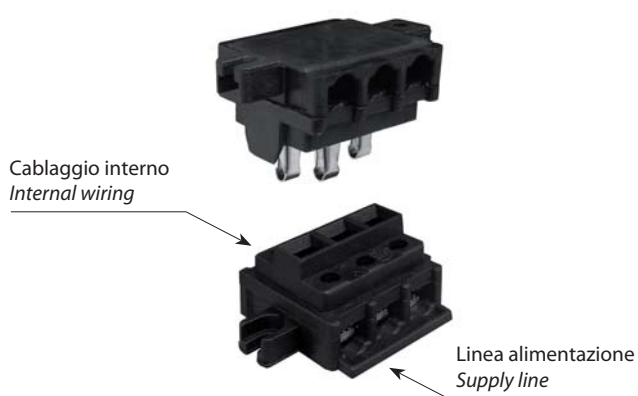

Basetta femmina (presa) Female terminal strip (plug)

Sezionatori

I sezionatori consentono il sezionamento automatico del cablaggio interno degli apparecchi illuminanti, dalla linea di alimentazione. Lo scopo è quello di consentire una manutenzione sicura e veloce dell'apparecchio già installato. Composti da una basetta femmina (presa), alimentata dalla rete e montata sulla parte fissa dell'apparecchio; e da una basetta maschio (spina) montata sulla parte apribile. Il cablaggio interno in genere è derivato dalla basetta femmina che è sempre fornita di adeguati morsetti. E' facoltà del cliente la scelta di avere o meno i morsetti di connessione anche sulla basetta maschio, qualora fosse necessario. All'atto dell'apertura, per manutenzione, il sezionatore interrompe automaticamente la linea di alimentazione, anche nel caso in cui l'operatore non abbia precedentemente aperto il circuito.

Disconnecting switches

Disconnecting switches are designed to automatically disconnect inside wiring from the mains supply in lighting fixtures. This allows quick and safe maintenance of the installed fixture. They are made up of a female terminal strip (plug), fed by the mains supply and fitted to the fixed part of the fixture, and a male terminal strip (socket) fitted to the opening side. The internal wiring is generally a derivation of the female terminal strip which is always equipped with suitable terminals. The customer can choose to have the connection terminals also on the male terminal strip, if required. When the fixture is opened for cleaning purposes, the switch disconnecter automatically cuts off the mains supply, even when the operator has not opened the circuit.

Serie 0125 - 0126 - 0127 - 0130 - 0131 - 0132

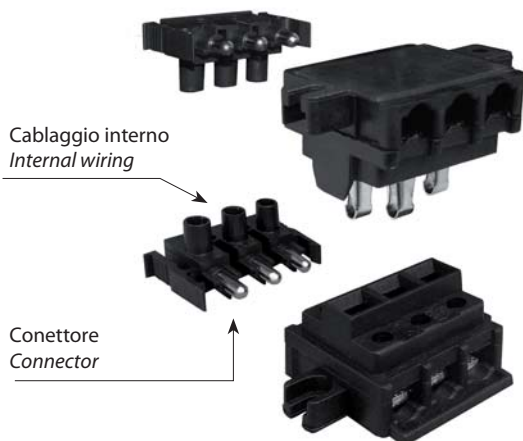

Sezionatori con attacco rapido

Oltre al sezionamento automatico descritto precedentemente, l'uso del connettore sul lato del cablaggio interno, mediante il sistema presa/spina, consente la sostituzione rapida dell'unità elettrica, quando per essa sia stata prevista la sua sostituzione senza l'uso di utensili. Sono disponibili per derivazione sia dalla basetta femmina che dalla basetta maschio.

Disconnecting switches with push-in connector

Besides acting as an automatic switch disconnecter as described above, the connector on the inside wiring side via the plug/socket system allows the electrical appliance to be replaced quickly without the need for any tools, when required. They are available by shunting from either the female or the male terminal strip.

Serie 0130 - 0131 - 0132

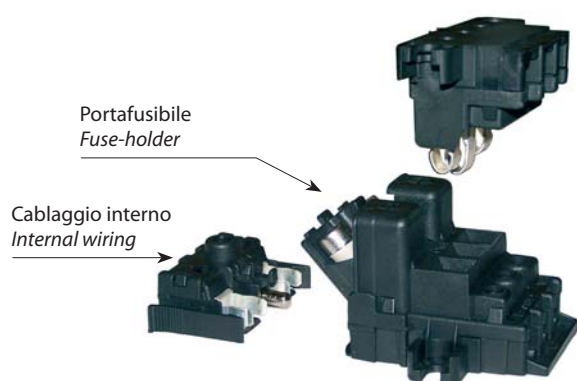

Sezionatori con portafusibile (Sistema brevettato)

Oltre al sezionamento automatico descritto precedentemente, la basetta femmina è dotata di due portafusibili per cartucce da 8.5x31.5 mm. Il portafusibile è integrato nella basetta in modo da non occupare un maggiore ingombro di una basetta standard. La basetta femmina è completata da apposito connettore ad aggancio rapido per la sostituzione senza l'uso di utensili dell'unità elettrica interna all'apparecchio.

Disconnecting switches with fuse-holder (Patented system)

The female terminal strip is equipped not only with the automatic isolation system described above, but also with two fuse-holders for 8.5x31.5 mm cartridges. The fuse-holders are integrated in the terminal strip and therefore the latter has the same dimensions as a standard terminal strip. The female terminal strip is also equipped with a connector and a quick-coupling system which make it possible to replace the terminal strip without having to use the tools of the internal electric unit of the appliance.

SEZIONATORI DISCONNECTING SWITCHES

250V

Versioni costruttive, dati tecnici

SERIE 0125 Sezionatore bipolare
SERIE 0126 Sezionatore tripolare
SERIE 0127 Sezionatore bipolare + terra

- Le serie 0125 - 0126 sono idonee al montaggio in apparecchi illuminanti di Classe II.
- Tutte le varianti dotate di fissacavo sono idonee al serraggio di cavi da 8,5 a 14 mm di diametro.
- A ciascuna serie può essere abbinato idoneo connettore per attacco rapido sul lato cablaggio interno.

Norma di riferimento: EN 60598-1



Dati elettrici

- Tensione nominale: 250V
- Corrente nominale: 16 A (10 A su richiesta)
- Temperatura ambiente max: T120
- Capacità connessione morsetti: 0,5 ÷ 4 mm² (0,75 ÷ 6 mm² su richiesta)

Materiali

- Corpo in poliammide 6.6 rinforzato con fibra di vetro al 25% e autoestinguente V0
- Contatti femmina in lamina di bronzo fosforoso nichelato
- Contatti maschio in lamina di bronzo fosforoso nichelato, conformati e rinforzati con riempimento di materiale plastico.
- Morsetti serrafilo standard a vite sottotesta con viti e dadi in acciaio zincato (0,5 ÷ 4 mm²)
- Su richiesta morsetti a bussola in ottone nichelato (0,75 ÷ 6 mm²) disponibili solo su basetta femmina.

Prove

Sono state eseguite prove contro i rischi di inserimento accidentale con risultati soddisfacenti nell'ambito degli scostamenti indicati nelle istruzioni di montaggio.

Constructive versions, specifications

SERIES 0125 two-pole disconnecting switch
SERIES 0126 three-pole disconnecting switch
SERIES 0127 two-pole disconnecting switch + earth

- Series 0125 and 0126 are suitable for installation in Class II lighting fixtures.
- All the variants with a cable clamp can be used to tighten 8.5 and 14mm diameter cables.
- Each series can be combined with a suitable push-in connector on the inside wiring.

Reference Standard: EN 60598-1



Electrical specifications

- Nominal voltage: 250 V
- Nominal current: 16 A (10 A on request)
- Max. ambient temperature: 120°C
- Terminal connection capacity: 0.5 ÷ 4mm² (0.75 ÷ 6mm² on request)

Materials

- 6.6 polyamide body reinforced with 25% fibreglass reinforcement and self-extinguishing class V0
- Female contacts made of nickel-plated phosphor bronze foil
- Male contacts made of nickel-plated phosphor bronze foil, shaped and reinforced with plastic filling
- Standard under-head screw cable clamp terminals with galvanized screws and nuts (0.5 ÷ 4 mm²)
- Nickel-plated brass 0.75 ÷ 6mm² bush terminals on request, only available with a female terminal strip

Tests

Tests on the risk of accidental insertion have been performed with satisfactory results, within the tolerances specified in the installation instructions

Schema di ingombro e montaggio
sezionatore serie 0125 - 0126 - 0127

Overall dimension and assembling chart
disconnecting switches series 0125 - 0126 - 0127

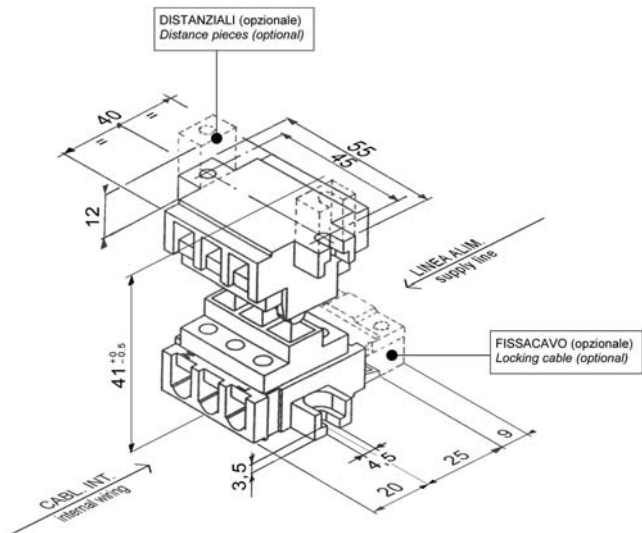

Schema di ingombro e montaggio con
connettore 2-3 poli

Overall dimension and assembling chart
2 pole, 3 pole connector

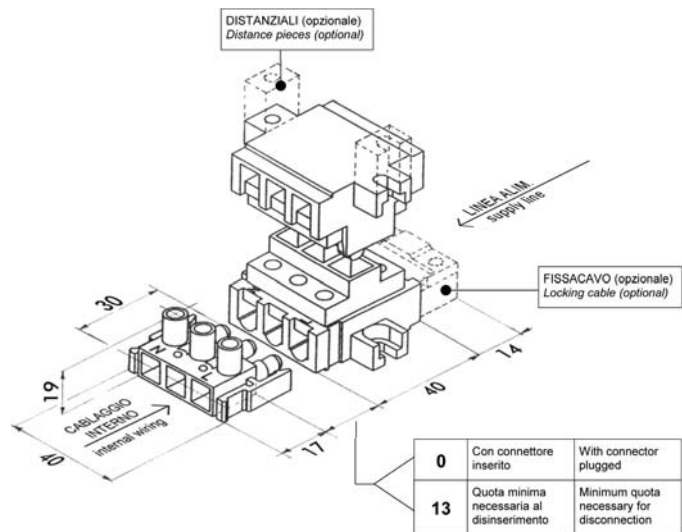

Serie/Series

0125

Sezionatori bipolari - 10A/16A - 250V - 4mm²
Two-pole disconnecting switch - 10A/16A - 250V - 4mm²

Basette femmina bipolari *Two-pole female bases*

COD. 0000012530

Basetta standard 10A
Standard base 10A

COD. 0000012531

Basetta standard 16A
Standard base 16A



COD. 0000012543

Basetta con fissacavo 10A
Base with locking cable 10A

COD. 0000012544

Basetta con fissacavo 16A
Base with locking cable 16A



Basette femmina bipolari con attacco rapido *Two-pole female bases with quick connection*

COD. 0000012572

Basetta standard 10A
Standard base 10A

COD. 0000012563

Basetta standard 16A
Standard base 16A



COD. 0000012573

Basetta con fissacavo 10A
Base with locking cable 10A

COD. 0000012562

Basetta con fissacavo 16A
Base with locking cable 16A



COD. ACC0012300

Connettore bipolare per sezionatore
Two-pole connector for disconnecting switches



Basette maschio bipolari *Two-pole male bases*

COD. 0000012534

Basetta standard senza morsetti serrafilo
Standard base without binding screw

COD. 0000012567

Basetta standard con morsetti serrafilo
Standard base with binding screw



COD. 0000012535

Basetta con distanziali, senza morsetti serrafilo
Male base with distance pieces, without binding screw

COD. 0000012568

Basetta con distanziali con morsetti serrafilo
Base with distance pieces, with binding screw



Basette maschio bipolari con attacco rapido *Two-pole male bases with quick connection*

COD. 0000012547

Basetta standard
Standard base



COD. 0000012548

Basetta con distanziali
Base with distance pieces



COD. ACC0012300

Connettore bipolare per sezionatore
Two-pole connector for disconnecting switches



Serie/Series

0126

Sezionatori tripolari - 10A/16A - 250V - 4mm²
Three-pole disconnecting switch - 10A/16A - 250V - 4mm²

Basette femmina tripolari *Three-pole female bases*

COD. 0000012630

Basetta standard 10A
Standard base 10A

COD. 0000012631

Basetta standard 16A
Standard base 16A



COD. 0000012643

Basetta con fissacavo 10A
Base with locking cable 10A

COD. 0000012644

Basetta con fissacavo 16A
Base with locking cable 16A



Basette femmine tripolari con attacco rapido *Three-pole female bases with quick connection*

COD. 0000012672

Basetta standard 10A
Standard base 10A

COD. 0000012663

Basetta standard 16A
Standard base 16A



COD. 0000012673

Basetta con fissacavo 10A
Base with locking cable 10A

COD. 0000012662

Basetta con fissacavo 16A
Base with locking cable 16A



COD. ACC0012400

Connettore tripolare per sezionatore
Three-pole connector for disconnecting switches



Basette maschio tripolari Three-pole male bases

COD. 0000012634

Basetta standard senza morsetti
Standard base without binding screw



COD. 0000012667

Basetta standard con morsetti serrafilo
Standard base with binding screw



COD. 0000012635

Basetta con distanziali, senza morsetti serrafilo
Base with distance pieces, without binding screw

COD. 0000012668

Basetta con distanziali con morsetti serrafilo
Base with distance pieces, with binding screw



Basette maschio tripolari con attacco rapido Three-pole male bases with quick connection

COD. 0000012647

Basetta standard
Standard base



COD. 0000012648

Basetta con distanziali
Base with distance pieces



COD. ACC0012400

Connettore tripolare per sezionatore
Three-pole connector for disconnecting switches



Serie/Series

0127

Sezionatori bipolari + terra - 10A/16A - 250V - 4mm²
Two-pole disconnecting switch + earth - 10A/16A - 250V - 4mm²

Basette femmina bipolari + terra *Two-pole female bases + earth*

COD. 0000012730

Basetta standard 10A
Standard base 10A

COD. 0000012731

Basetta standard 16A
Standard base 16A



COD. 0000012743

Basetta con fissacavo 10A
Base with locking cable 10A

COD. 0000012744

Basetta con fissacavo 16A
Base with locking cable 16A



Basette femmina bipolari + terra con attacco rapido *Two-pole female bases + earth with quick connection*

COD. 0000012772

Basetta standard 10A
Standard base 10A

COD. 0000012763

Basetta standard 16A
Standard base 16A



COD. 0000012773

Basetta con fissacavo 10A
Base with locking cable 10A

COD. 0000012762

Basetta con fissacavo 16A
Base with locking cable 16A



COD. ACC00124A0

Connettore bipolare con terra per sezionatore
Two-pole connector with earth for disconnecting switches



Basette maschio bipolari + terra *Two-pole male bases + earth*

COD. 0000012734

Basetta standard senza morsetti serrafilo
Standard base without binding screw

COD. 0000012767

Basetta standard con morsetti serrafilo
Standard base with binding screw



COD. 0000012735

Basetta con distanziali senza morsetti serrafilo
Base with distance pieces, without binding screw

COD. 0000012768

Basetta con distanziali con morsetti serrafilo
Base with distance pieces, with binding screw



Basette maschio bipolari + terra con attacco rapido *Two-pole male bases + earth with quick connection*

COD. 0000012747

Basetta standard
Standard base



COD. 0000012748

Basetta con distanziali
Base with distance pieces



COD. ACC00124A0

Connettore bipolare con terra per sezionatore
Two-pole connector with earth for disconnecting switches



SEZIONATORI DISCONNECTING SWITCHES

400V

Versioni costruttive, dati tecnici

SERIE 0130 Sezionatore bipolare
SERIE 0131 Sezionatore tripolare
SERIE 0132 Sezionatore bipolare + terra

- Le serie 0130 – 0131 sono idonee al montaggio in apparecchi illuminanti di Classe II.
- Tutte le varianti dotate di fissacavo sono idonee al serraggio di cavi da 8 a 14 mm di diametro.
- A ciascuna serie può essere abbinato idoneo connettore per attacco rapido sul lato cablaggio interno.

Norma di riferimento:
Per sezionatore: EN 60598-1



Per portafusibile EN60269-1 EN60269-3 CEI 32-13
In corso di approvazione presso IMQ

Dati elettrici sezionatori

- Tensione nominale: 400V
- Corrente nominale: 16 A
- Temperatura ambiente max: T 140
- Capacità connessione morsetti: $0,5 \div 4 \text{ mm}^2$
($0,75 \div 6 \text{ mm}^2$ su richiesta)

Dati elettrici portafusibile

- Tensione nominale: 400V
- Corrente nominale: 16 A
- Potenza nominale ammissibile: 2,3W
- Dimensioni cartucce fusibile: 8,5x31,5 mm
- Capacità connessione morsetti: $0,5 \div 4 \text{ mm}^2$

Materiali

- Corpo in poliammide 6.6 rinforzato con fibra di vetro al 25% e autoestinguento V0
- Contatti basetta femmina in lamina di bronzo fosforoso nichelato
- Contatti basetta maschio in lamina di bronzo fosforoso argentato, conformati e rinforzati con riempimento di materiale plastico.
- Contatti portafusibili in lamina di bronzo fosforoso argentato
- Morsetti serrafilo standard a vite sottotesta con viti e dadi in acciaio zincato ($0,5 \div 4 \text{ mm}^2$)
- Su richiesta morsetti a bussola in ottone nichelato ($0,75 \div 6 \text{ mm}^2$) disponibili solo su basetta femmina.

Prove

Sono state eseguite prove contro i rischi di inserimento accidentale con risultati soddisfacenti nell'ambito degli scostamenti indicati nelle istruzioni di montaggio.

Nota importante

La basetta femmina con portafusibile è dotata di apposito connettore ad aggancio rapido indispensabile al collegamento con il cablaggio interno. L'aggancio e lo sgancio di tale connettore va sempre fatto con il portafusibile aperto.

Constructive versions, specifications

SERIES 0130 two-pole disconnecting switch
SERIES 0131 three-pole disconnecting switch
SERIES 0132 two-pole disconnecting switch + earth

- Series 0130 and 0131 are suitable for installation in Class II lighting fixtures.
- All the variants with a cable clamp can be used to tighten 8 and 14mm diameter cables.
- Each series can be combined with a suitable push-in connector on the inside wiring.

Reference standards
Disconnecting switch: EN 60598-1



Fuse-holder: EN60269-1 EN60269-3 CEI 32-13
Approval by IMQ underway

Electrical specifications: switches

- Nominal voltage: 400 V
- Nominal current: 16 A
- Max. ambient temperature: 140°C
- Terminal connection capacity: $0,5 \div 4 \text{ mm}^2$
($0,75 \div 6 \text{ mm}^2$ on request)

Electrical specifications: fuse-holder

- Nominal voltage: 400 V
- Max nominal current: 16 A
- Nominal Power: 2,3W
- Fuses dimensions: 8,5x31,5 mm
- Terminal connection capacity: $0,5 \div 4 \text{ mm}^2$

Materials

- 6.6 polyamide body reinforced with 25% fibreglass reinforcement and self-extinguishing class V0
- Female contacts made of nickel-plated phosphor bronze foil
- Male contacts made of silver-plated phosphor bronze foil, shaped and reinforced with plastic filling
- Fuse-holder contacts made of silver plated bronze foil
- Standard under-head screw cable clamp terminals with galvanized screws and nuts ($0,5 \div 4 \text{ mm}^2$)
- Nickel-plated brass $0,75 \div 6 \text{ mm}^2$ bush terminals on request, only available with a female terminal strip

Tests

Tests on the risk of accidental insertion have been performed with satisfactory results, within the tolerances specified in the installation instructions.

Important note

The female terminal strip with fuse-holder is equipped with a quick-coupling connector which is indispensable for the connection to the internal wiring. The coupling and detachment of this connector must be carried out when the fuse-holder is open.

Schema di ingombro e montaggio sezionatori serie 0130 - 0131 - 0132

Overall dimension and assembling chart disconnecting switches series 0130 - 0131 - 0132

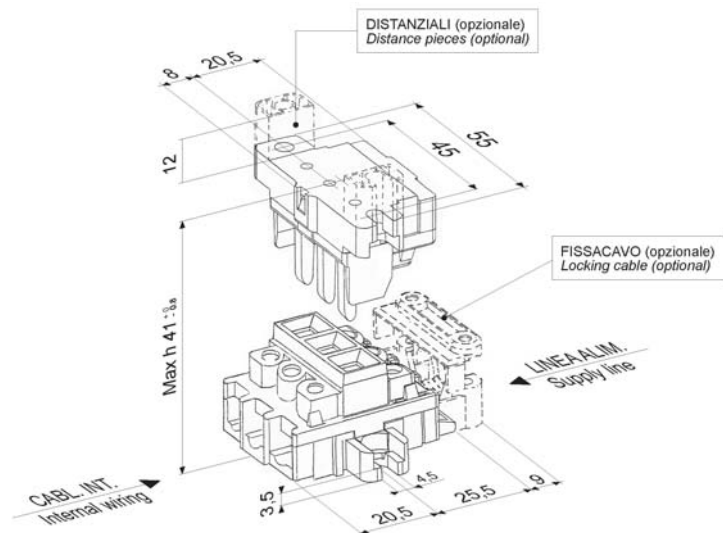

Schema di ingombro e montaggio con connettore 2-3 poli

Overall dimension and assembling chart 2 pole, 3 pole connector

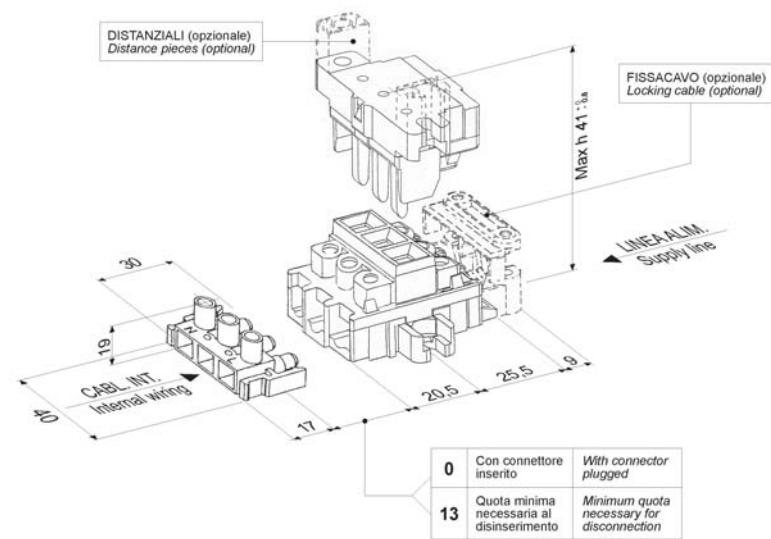

Schema di ingombro e montaggio con basetta portafusibile

Overall dimension and assembling chart with fuse-holder terminal strip

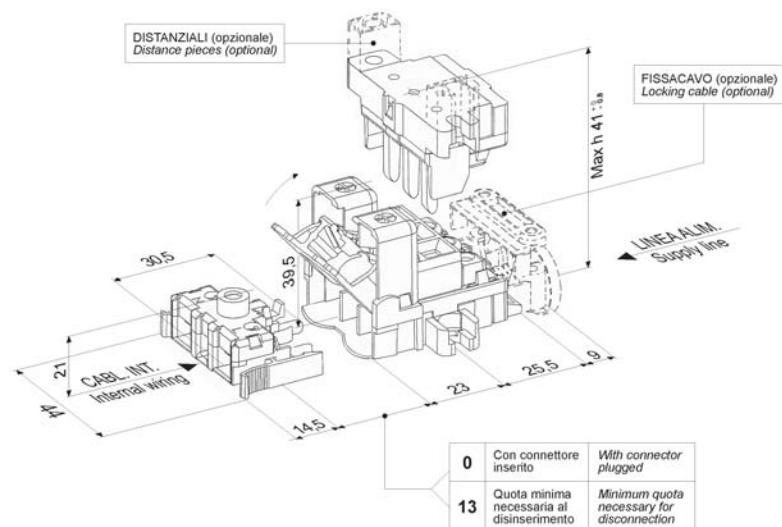

Serie/Series

0130

Sezionatori bipolari 16A - 400V - 4mm²
Two-pole disconnecting switch 16A - 400V - 4mm²

Basette femmina bipolari *Two-pole female bases*

COD. 0000013050

Basetta standard
Standard base



COD. 0000013051

Basetta con fissacavo
Base with locking cable



Basette femmina bipolari con attacco rapido *Two-pole female bases with quick connection*

COD. 0000013054

Basetta standard
Standard base



COD. 0000013055

Basetta con fissacavo
Base with locking cable



COD. ACC0012300

Connettore bipolare per sezionatore
Two-pole connector for disconnecting switches



Basette femmina bipolari con portafusibili

Two-pole female bases with fuse-holders

COD. 0000013005

Basetta standard
Standard base

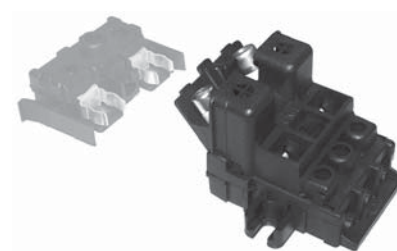

COD. 0000013006

Basetta con fissacavo
Base with locking cable

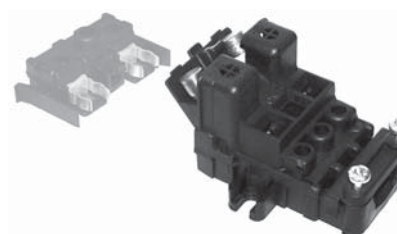

COD. 0000013010

Connettore bipolare per basetta portafusibili
Two-pole connector for fuse-holder base



Basette maschio bipolari

Two-pole male bases

COD. 0000013011

Basetta standard senza morsetti serrafilo
Standard base without binding screw



COD. 0000013013

Basetta con morsetti serrafilo
Standard base with binding screw



COD. 0000013012

Basetta con distanziali, senza morsetti serrafilo
Standard base with distance pieces, without binding screw

COD. 0000013014

Basetta con distanziali con morsetti serrafilo
Base with distance pieces, with binding screw

Serie/Series

0131

Sezionatori tripolari 16A - 400V - 4mm²
Three-pole disconnecting switch 16A - 400V - 4mm²

Basette femmina tripolari *Three-pole female bases*

COD. 0000013150

Basetta standard
Standard base



COD. 0000013151

Basetta con fissacavo
Base with locking cable



Basette femmina tripolari con attacco rapido *Three-pole female bases with quick connection*

COD. 0000013154

Basetta standard
Standard base



COD. 0000013155

Basetta con fissacavo
Base with locking cable



COD. ACC0012400

Connettore tripolare per sezionatore
Three-pole connector for disconnecting switches



Basette femmina tripolari con portafusibili

Three-pole female bases with fuse-holders

COD. 0000013105

Basetta standard
Standard base

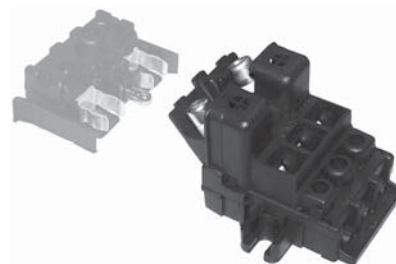

COD. 0000013106

Basetta con fissacavo
Base with locking cable

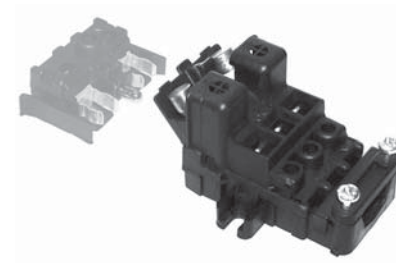

COD. 0000013110

Connettore tripolare per basetta portafusibili
Three-pole connector for fuse-holder base



Basette maschio tripolari

Three-pole male bases

COD. 0000013111

Basetta standard senza morsetti serrafilo
Standard base without binding screw



COD. 0000013113

Basetta con morsetti serrafilo
Standard base with binding screw



COD. 0000013112

Basetta con distanziali, senza morsetti serrafilo
Standard base with distance pieces, without binding screw

COD. 0000013114

Basetta con distanziali con morsetti serrafilo
Base with distance pieces, with binding screw

Serie/Series

0132

Sezionatori bipolari + terra 16A - 4050V - 4mm²
Two-pole disconnecting switch + earth 16A - 400V - 4mm²

Basette femmina bipolare + terra
Two-pole female bases + earth

COD. 0000013250

Basetta standard
Standard base



COD. 0000013251

Basetta con fissacavo
Base with locking cable



Basette femmina bipolari + terra con attacco rapido
Two-pole female bases + earth with quick connection

COD. 0000013254

Basetta standard
Standard base



COD. 0000013255

Basetta con fissacavo
Base with locking cable



COD. ACC00124A0

Connettore bipolare + terra per sezionatore
Two-pole connector with earth for disconnecting switches



Basette femmina bipolare + terra con portafusibili

Two-pole female bases + earth with fuse-holders

COD. 0000013205

Basetta standard
Standard base

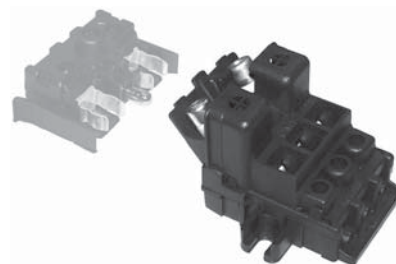

COD. 0000013206

Basetta con fissacavo
Base with locking cable

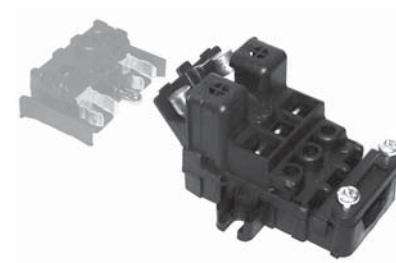

COD. 0000013110

Connettore bipolare per basetta portafusibili
Two-pole connector for fuse-holder base



Basette maschio bipolari + terra

Two-pole male bases + earth

COD. 0000013211

Basetta standard senza morsetti serrafilo
Standard base without binding screw



COD. 0000013213

Basetta standard con morsetti serrafilo
Standard base with binding screw

COD. 0000013212

Basetta con distanziali, senza morsetti serrafilo
Standard base with distance pieces, without binding screw



COD. 0000013214

Basetta con distanziali con morsetti serrafilo
Base with distance pieces, with binding screw

Design by
Telonius Whitehead
2009



OMT S.R.L.
Via Tito Speri 7/E
25040 Nigoline di Cortefranca (BS)
tel. 030984128 - 030984181
fax 030984256
info@omtsrl.com
C.F./P. IVA 00219160173

www.omtsrl.com